

1. SIGNALS MADE ASHORE

- 1.1 Notices to competitors will be posted on the official notice board on the RYC website.
- 1.2 Signals made ashore will be displayed on the flagpole north of the RYC Clubhouse.
- 1.3 When Flag AP displayed ashore is lowered, '1 minute' is replaced with 'not less than 45 minutes' in the race signal AP,
- 1.4 In the event any change(s) to the Sailing Instructions are posted, the Race Committee shall endeavor to signal the change by displaying code flag L ashore. Failure to display code flag L shall not be grounds for redress.
- 1.5 Any change to the sailing instructions will be posted before 1400 on the day it takes effect.

2. CHECK IN and RADIO COMMUNICATIONS

- 2.1 Each boat intending to race shall check in with the Signal Boat prior to the first warning signal.
- 2.2 On the water, the race committee will monitor and communicate with competitors on VHF radio channel 72. Failure to make an announcement shall not be grounds for redress.
- 2.3 [DP] While racing, except in an emergency, a boat shall not make voice or receive voice or data transmissions not freely available to all boats.

3. RACE SCHEDULE

- 3.1 Tuesday races begin on May 16, 2023.
- 3.2 Twenty-two (22) race days are scheduled, divided into three series - Spring, Summer, and Fall.
- 3.3. When more than one race is held on the same day, the warning signal for each succeeding race shall be made as soon as practicable.
- 3.4 Starting Times

May thru August			September		
Class	Flag	1st Warning	Class	Flag	1st Warning
Melges 15	M15	18:30	Melges 15	M15	18:00
J/24	J/24	18:35	J/24	J/24	18:05
Sonar	Sonar	18:40	Sonar	Sonar	18:10

4. COURSES & MARKS

- 4.1 The configuration of courses are shown in Attachment 1.
- 4.2 The course to be sailed for each race will be signaled by placards displayed on the signal boat.
- 4.3 Marks will be orange, yellow, red or green tetrahedrons or cylinders.

5. THE START

- 5.1 The approximate location of the starting area will be 1 NM ENE of the Summerville Pier.
- 5.2 Races will be started in accordance with RRS Appendix U Audible-Signal Racing System.
- 5.3 The starting line will be between the orange flag on the signal boat and the nearby starting mark.
- 5.4 [DPI Boats whose warning signal has not been made shall avoid the starting area.
- 5.5 The race committee will attempt to hail premature starters by sail numbers, boat name, or bow numbers. Failure to hail, failure to hear a hail, or the order in which boats are hailed, will not be grounds for redress.

6. OBSTRUCTIONS

- 6.1. On legs of the course from W to L, the start line, and marks, taken together, is an obstruction when the orange flag is displayed. On legs of the course from W to L, the finish line and marks, taken together, is an obstruction when the blue flag is displayed.

7. THE FINISH

- 7.1 The finish line will be between the blue flag on the signal boat and the nearby finishing mark.
- 7.2 If the RC intends to start another race on the same day, it will display the Second Substitute while boats are finishing.

8. TIME LIMITS

- 8.1. The time limit for each race shall be 60 minutes from that class's start.
- 8.2. Any boat not starting within 3 minutes of her starting signal for a race will be scored DNS for that race. This changes RRS 35 and A4.

9. PENALTIES

- 9.1. RRS Appendices VI and V2 shall apply.

10. WITHDRAWAL

- 10.1. A boat that retires from a race shall notify the Race Committee by hail, VHF radio, or in person.

11. MEASUREMENT

- 11.1. [DP] A boat or equipment may be inspected at any time for compliance with the class rules and sailing instructions.

12. SCORING

- 12.1 RRS A5.3 applies.
- 12.2 At least two boats in a division must start a race for it to qualify for Series Scoring for that division.
- 12.3 Three races must be completed to constitute a series.



- 12.4 Each boat's series score shall be the total of her race scores excluding her worst score once four races have been scored. This modifies RRS A2.1.
- 12.5 AVE: If the boat is competing in an away Class Regatta, the boat may be scored the average of her other starts in the series, limited to one race day per series.
 - ** Any boat that qualifies for scoring under AVE, must notify the Racing Fleet Captain prior to the race to be eligible for average finish scoring.
- 12.6 Refer to 2023 RYC Scoring Addendum for details on Class Season Championship Scoring.

13. HEARING REQUESTS

- 13.1 Hearing request forms may be filed in writing at the RYC bar, or with the Racing Fleet Captain.
- 13.2 The time limit for filing hearing requests is 60 minutes after the Race Committee boat docks.
- 13.3 RRS 62.2(a) and 66.2(a) do not apply.

Attachment #1 — ONE DESIGN COURSE DIAGRAMS

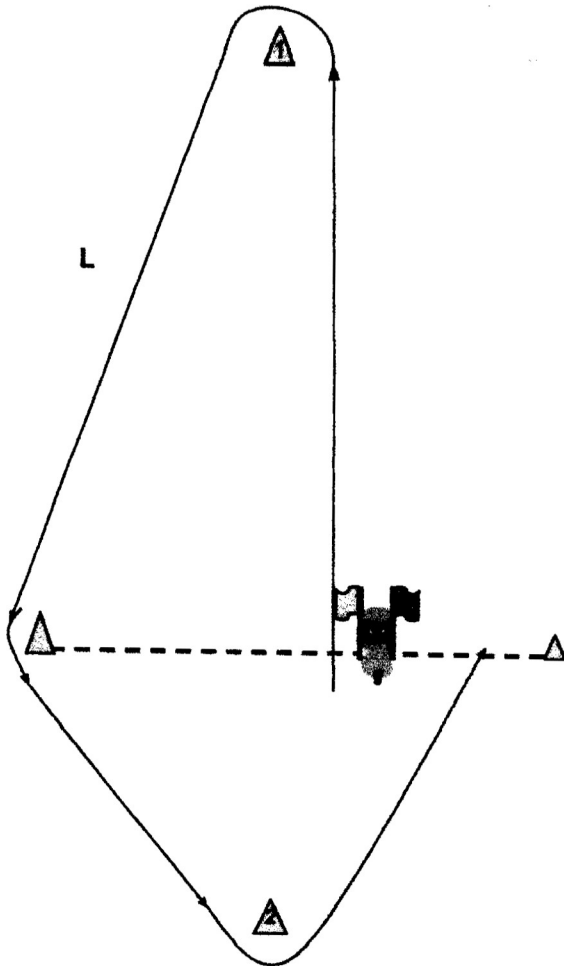

L: Start > 1 > 2 > Finish

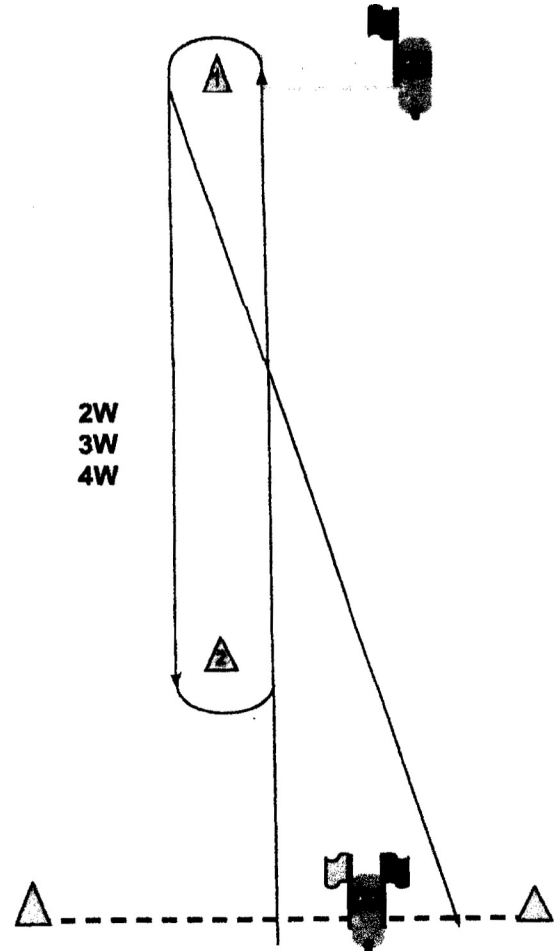

2W: Start > 1 > Finish

3W: Start > 1 > 2 > Finish

4W: Start > 1 > 2 > 1 > Finish

Note that the finish of course 3W is at mark 1